

A-584 Rzut ławki 1:20

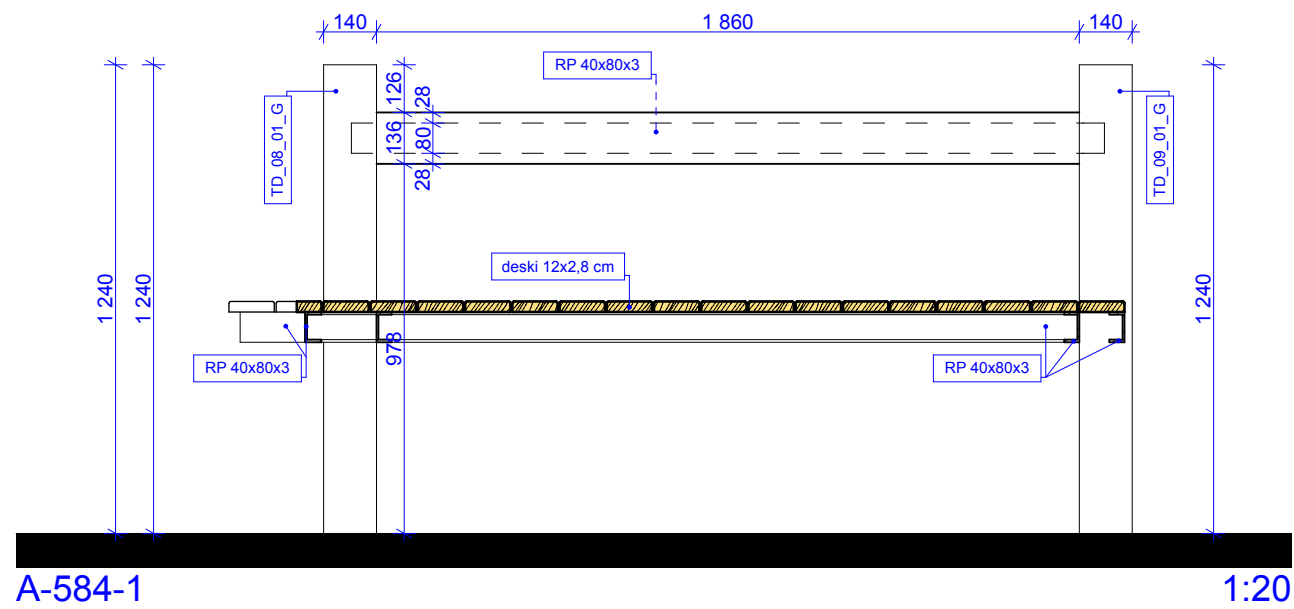

A-584-1 1:20

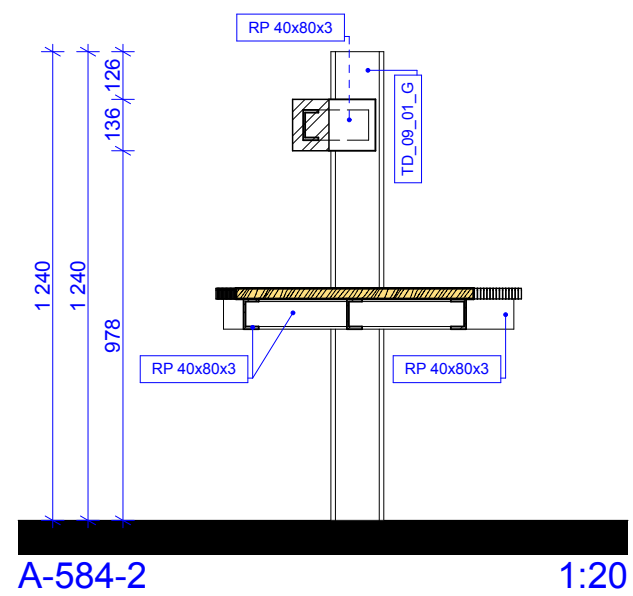

A-584-2 1:20

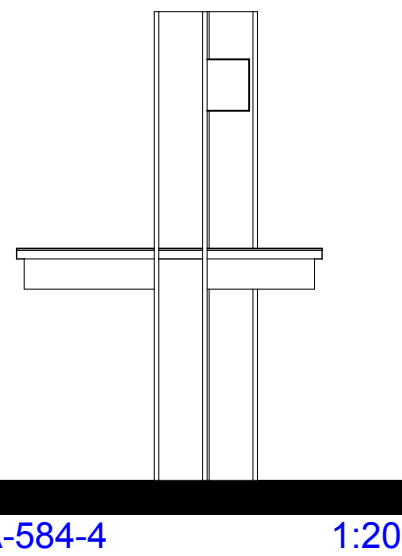

A-584-4 1:20

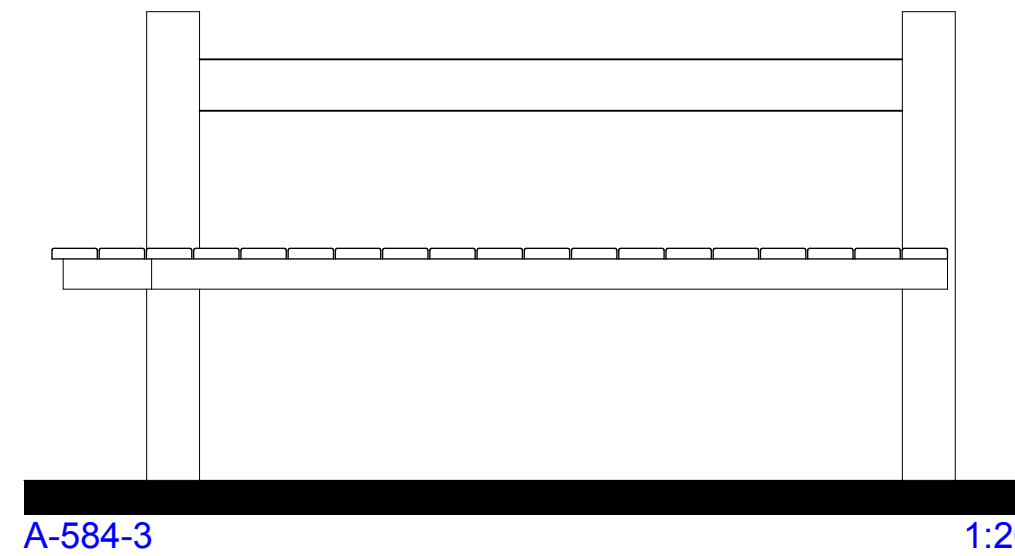

A-584-3 1:20

ul. Pszowska
nr. działek: 683/7, 2246/168,
2247/168, 865/7
44-370 Pszów

P_02

Projekt wykonawczy rewitalizacji
rynku_PSZOW_ETAP II

Architektura_Konstrukcja
A-5_Detale - Mała Architektura

Ławka

A-584

1:20,

29.09.2014 04:04